



LASER RANGEFINDER MODULE DL-20 000

Technical description and Operator's Manual

No LRF "DL-20 000 "No XXXXX



www.laseropttronix.se

CONTENTS

Introduction

The table of contents is empty because none of the paragraph styles selected in the Document Inspector are used in the document.

CERTIFICATE

Technical description and Operator's Manual is intended to familiarize the user with the principle of operation, construction, functioning and proper operation of laser rangefinder module (further referred to as 'laser rangefinder module' or 'DL-20 000').

Principle of operation of laser rangefinder module is based on measuring the time taken by a light signal generated by laser rangefinder module transmitter to reach the target and come back.

1 DESCRIPTION AND USE OF LASER RANGEFINDER MODULE DL20000

1.1 Purpose

1.1.1 Laser rangefinder module is intended for measuring the distance to a target situated in the field of view of the transmitting objective.

1.1.2 DL-20 is powered from a power source with nominal voltage **12 V**.

1.2 Technical characteristics

Technical characteristics of laser rangefinder module are listed in table 1.

Table 1

| Basic parameters and characteristics | Value |
|---|---------------------|
| Operating emission wavelength, μm | 1,067 |
| Laser radiation energy, mJ, not less than | 30 |
| Operation range, m, (for a big target) - atmospheric visibility range - 20 000 m | 100 –20 000 |
| Measurement accuracy, m | ± 3 |
| Input voltage, V | 12 |
| Continuous operation time, s (pause, s) | 30 (30) |
| Number of cycles | 6 |
| Operating temperature, $^{\circ}\text{C}$ | Minus 30 ...plus 55 |
| Storage temperature, $^{\circ}\text{C}$ | Minus 40...plus 70 |
| Relative humidity, up to % | 90 |
| Air pressure, kPa | (101 \pm 20) |
| Interface | RS 422 |
| Overall dimensions, mm, not more than | 60x130x240 |
| Weight, kg, not more than | 3.4 |

.3 Complete set

Complete set shall comply with the list in table 2

Table 2

| Name | Q-ty | Note |
|---|------|------------------------|
| Laser rangefinder module "DL-20" | 1 | |
| Cover | 2 | |
| Extender 9M/9Π | 1/12 | One piece for 12 units |
| USB-adapter in COM KIT BM8050 | 1/12 | One piece for 12 units |
| Socket 2PM24KΠH19Γ1B1 | 1 | |
| Cable | 1 | |
| PC Board with software 6785.00.00.900 | 1/12 | One piece for 12 units |
| Technical description and Operator's Manual | 1 | |

1.4 Composition of laser rangefinder module

Laser rangefinder module consists of (figure 1.1) the following basic parts:

- transmitter-receiver module (TRM) 1;
- cable №1 - for connecting of DL-20 to external power source 12 V and to the external control device (ECD) 3 of the User or to the personal computer. TRM has one socket for connection of a cable 1. Electric connection of a cable 1 to TRM is carried out as per the scheme of connections (figure 4) and table 3 taking into account requirements of item 2.2.2 "the Order of laser rangefinder module installation on object ". Laser rangefinder module control is carried out with ECD of the User or from a personal computer. Laser rangefinder module operation mode is set by control commands.

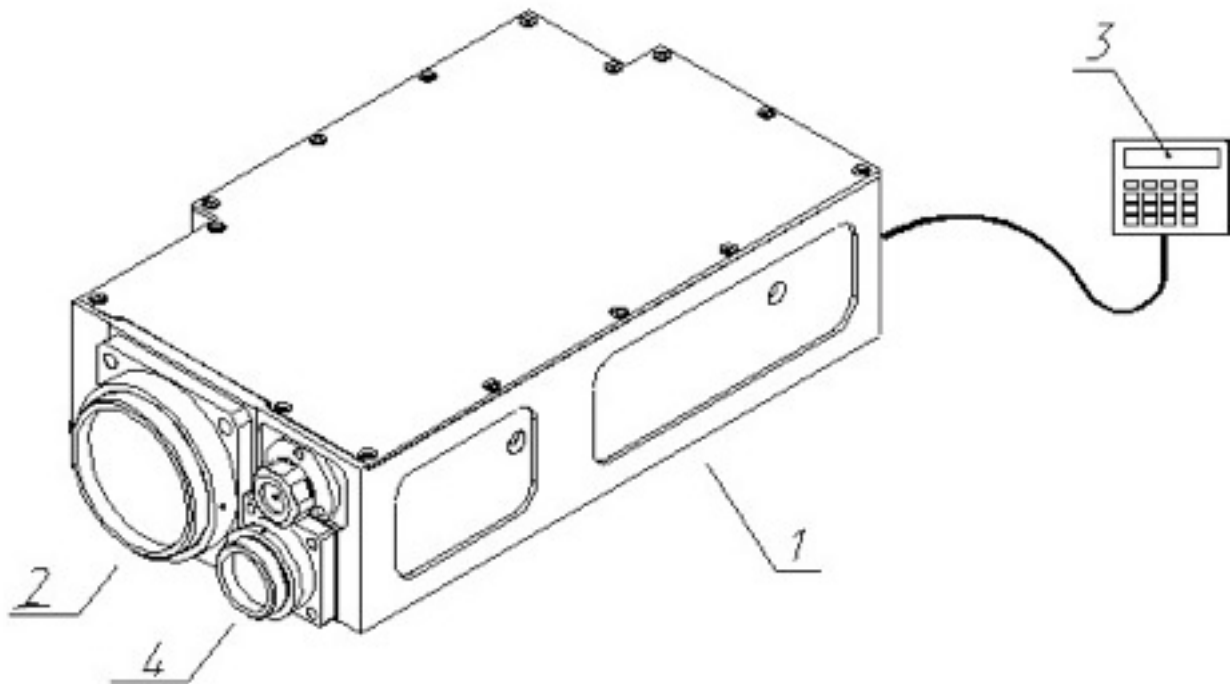

1 – transmitter-receiver module (TRM)

- 2 – receiver channel
- 3 – external control device (ECD)
- 4 - transmitter channel

Figure 1 – Laser rangefinder module complete set

1.5 Principle of laser rangefinder module operation

Laser rangefinder module can be functionally divided (Figure 2) into two channels: transmitting channel (4 Figure 1) and receiving channel (2 Figure 1).

Transmitting channel emitter generates a pilot pulse with the wavelength $1.067 \mu\text{m}$, approximate length 15 ns and energy 20 mJ. Pilot pulse, when passing through the atmosphere, is reflected from all targets situated in the field of view of the transmitting channel. Light pulses reflected from the targets get to the input objective of receiving channel and are detected by avalanche photodiode (APD). APD electrical signals function as stop pulses for time intervals measurement unit (TIMUC) of laser rangefinder module.

Part of transmitting channel emitter pilot pulse energy is drawn through the fiber to transmitting channel APD and functions as start pulse for TIMU.

Distance to the targets is determined on the basis of delay time of stop signal reflected from the target against pilot pulse – start signal.

Distance to the target is calculated by formula:
 $D=C \cdot \Delta t / 2, \text{m};$

where D – measured distance;

C = 299792458 m/c – light velocity;

Δt – measured time between start pulse and the corresponding stop pulse.

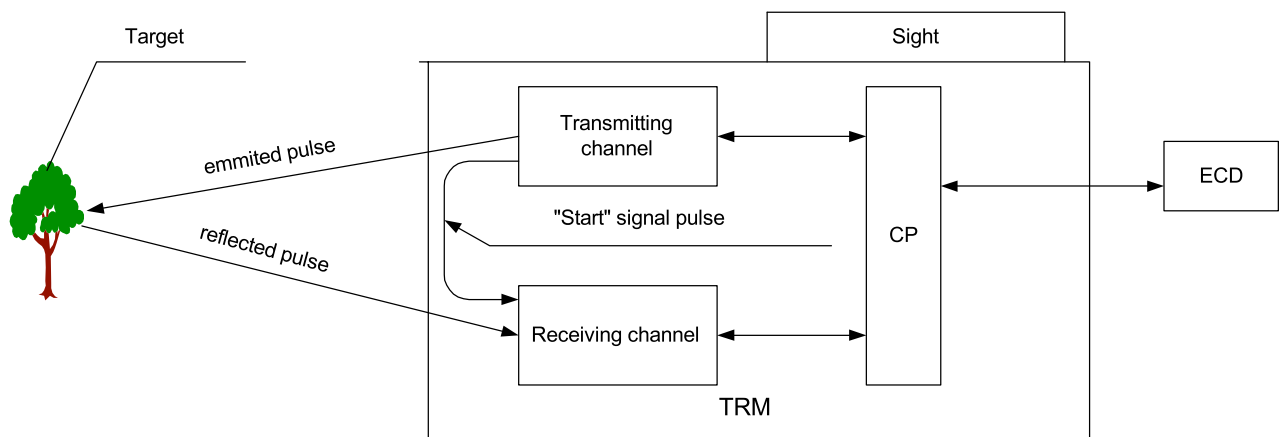

Figure 2 - Laser rangefinder module functional diagram

2 PROPER USE

2.1 Safely measures during laser rangefinder module operation

Design of laser rangefinder DL20 000» ensures safety for personnel while performing assembling and adjusting jobs.

Only personnel who have studied the present Operation manual are allowed to work with the laser rangefinder.

Only personnel who have been instructed and trained about how to operate lasers are allowed to assemble laser rangefinder and to carry out inspection test.

Observe requirements of warning signs on laser rangefinder body when carrying out assembling and inspection test.

When operating laser rangefinder safety measures must be strictly observed so as to avoid exposure of radiation into eyes.

No things having mirror or close to mirror reflecting surfaces can be located inside laser beam when operating laser rangefinder.

Cover TRM optics when carrying out jobs connected with light pulses radiation indoors.

WHEN LASER RANGEFINDER MODULE IS SWITCHED ON IT IS STRICTLY FORBIDDEN TO STAND IN FRONT OF IT, TO EXAMINE OPTICAL PARTS (FROM THE SIDE OF OBJECTIVES), TO DISCONNECT CONNECTING CABLES.

2.2 Preparation of laser rangefinder for operation

2.2.1 Scope and order of external examination

Before assembling laser rangefinder on object it is necessary to unpack, reactivate and to examine laser rangefinder.

Examination includes:

- checking of optical parts surfaces.

Presence of cracks, fat stains and dust on protective glasses and lenses as well as sweating of inner surfaces are not allowed;

In case of presence of fat stains and dust on protective glasses and lenses do as per item 3.1.

2.2.2 The Order of laser rangefinder module installation on object .

2.2.2.1. Mount DL-20 on the mounting seat on the object, which is to be provided with two pins $\varnothing 6h9$ mm. The pins are to get into the openings in heels 2 of DL-20 body (figure 3). Fix DL-20 body with three M6 screw-bolts, threaded openings for which are available in supports 1.

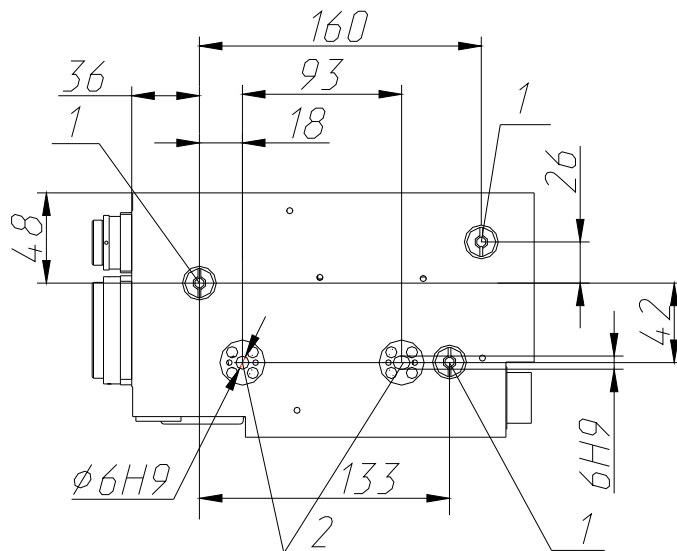
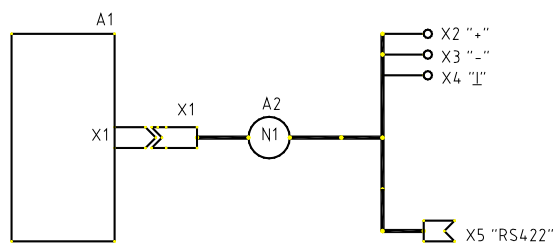

Figure 3 – DL-20 000 (bottom view)

2.2.2.2 Plug in user's cable of necessary size to port X1 of the TRM body using socket 2PM24KIIH19Г1B1 and assignment of contacts stated in table 2.1 and in Figure 4.



A1 – combined module (CM)
 A2 - cable №1 (technological)

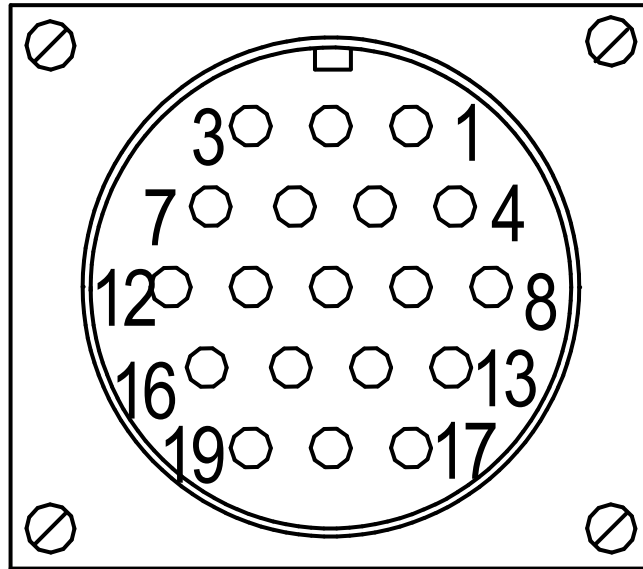

Figure 4 – Connection diagram

ATTENTION! LASER RANGEFINDER MODULE IT IS SWITCHED ON BY SUPPLYING POWER VOLTAGE..

2.2.2.3 Make sure that the power supply is switched off.

2.2.2.4 Plug user's cable to TRM as per table 2.1.

2.2.2.5 When connecting DL-20 to the cable of the Customer it is necessary to be guided by assignment of contacts of DL-20 socket in table 2.1

Table 2.1

| The name of a circuit | Number contact of socket DL-20 | the Note |
|-----------------------|--------------------------------|---|
| +9...12 V | 14 | Maximal current on contact 3A |
| +9...12 V | 15 | Maximal current on contact 3A |
| +9...12 V | 16 | Maximal current on contact 3A |
| -9...12 V | 17 | Maximal current on contact 3A |
| -9...12 V | 18 | Maximal current on contact 3A |
| -9...12 V | 19 | Maximal current on contact 3A |
| A | 1 | RS422 + an input of the receiver |
| B | 2 | RS422 - an input of the receiver |
| COMAB | 3 | RS422 the core screen of input signals |
| Z | 5 | RS422 + an output of the transmitter |
| Y | 6 | RS422 - an output of the transmitter |
| COMYZ | 7 | RS422 the core screen of output signals |
| COMSYNH | 9 | the core screen synchro pulses signals |
| SYNH+ | 10 | + an input of synchronization |
| SYNH- | 11 | - an input of synchronization |

2.2.2.6 After installation of DL-20 on object DL-20 channels should be matched with the channel in system of the Customer with a margin error no more than 1 ang. min.

Make superposition (matching) of the device's channels with the homing channel of system of the Customer's system using the optical sight and system of azimuth and elevation correction of mounting surface where the device is installed.

In order to achieve this, make superposition of the aiming mark of device's optical sight with a target situated on distance of 2 km using the mechanism of aiming of the mounting surface.

Carry out distance measurement to various targets

2.3 Use of laser rangefinder module

Laser rangefinders are commanded via serial interface RS422.

In addition to this, there is an input of external synchronization which is electrically compatible with RS 422 signals. Depending on the type of command, the following types of synchronization are possible:

1. Cycle of measurement begins after the receipt of appropriate command. Each command means one measurement.
2. Cycle of measurement begins by positive-going edge on the input of external synchronization.
3. Cycle of measurement begins independently; measurements are carried out with specified frequency and during specified time. Repetition period, in milliseconds, and operation time, in seconds, are set by one command.

The serial interface is set up as follows:

Exchange speed – 38400 baud, symbol – 8 bit, parity check is enabled, parity – even.

All the control commands of the laser rangefinder begin with byte with value 0xDC and end with byte containing 0xBE. For data transfer packed binary-decimal format is used. Since while using this format each half of the byte contains codes from 0 to 9 – presence of symbol with code from 0xA to 0xF allows to easily assign controlling symbols in the stream of transferred data. So, for example, byte 0xDC always means the beginning of a new command or transferred data block. Order of symbols in data fields – high-order symbols are to the left. For example, the distance of 12345 meters is coded is three bytes as follows: 0x12, 0x34, 0x50, and the distance of 987 meters: 0x00, 0x98, 0x70.

Data packets transmitted by the laser rangefinder can be of various types, moreover the same data packet, for example distance, can be transmitted after the receipt of different control commands. Type of the present packet can be determined by the value of the second byte of the packet. If the byte which follows the start byte equals 0xA1 – this means transfer of distance, if 0xA3 – this is the data on number of pulses and performance period of the device, if 0xA4 – data on condition of sensors of the device. This provides good flexibility for development of control software, as for correct display of received data information about the last sent command or synchronization with it is not needed.

Structure of data packets transferred by the laser rangefinder to control device:

1. Distances. 0xDC, 0xA1, Rg11 Rg12, Rg13 Rg14, Rg15 Rg16, Rg21 Rg22, Rg23 Rg24, Rg25 Rg26, Rg31 Rg32, Rg33 Rg34, Rg35 Rg36, 0xBE.

Here Rg means binary-decimal symbol occupying half of a byte. First index – number of distance, second – number of symbol in distance in decimal writing. Sixth symbol has 10 cm ratio and always equals 0 (Reserved for increasing accuracy).

Example: 2 targets 1024 and 2048 meters.

0xDC, 0xA1, 0x01, 0x02, 0x40, 0x02, 0x04, 0x80, 0x99, 0x99, 0x99, 0xBE.

Value of 99999.9 meters in position of distance number three means a miss, in other words absence of third target. Always three distances are transmitted, they are always sorted by increment, value 0x99, 0x99, 0x99 means that relative counter of time intervals gauge has counted to maximum value and signal from a target was not received, i.e. a miss. Besides, zero values of all distances is the sign of absence of start pulse – internal error of the range-

- 2.4.3 To take a min. 10 second pause to prepare the device for operation.
- 2.4.4 To carry out distance measurements.
- 2.4.6 To switch off power supply after the end of measurements.
- 2.4.8 To close transmitting and receiving channels with protective covers.

2.5 List of possible malfunctions in the process of operation and recommendations on troubleshooting.

2.5.1 If a malfunction was detected during operation of the device or some of its components it is necessary to check:

- correctness of mount of the device on an object;
- presence of dust on protective glass of the objectives;
- correctness of cable connection and condition of the cable;
- value of voltage of device's power supply and power of power source.

2.6 Testing of the laser rangefinder using personal computer.

For testing the rangefinder from personal computer via COM port technological cable №1, converter board 6785.00.00.900 and extender 9M/9Π are used. For testing via USB port additional converter board USB to COM. KIT BM8050 is provided. Program for control of the rangefinder is provided on a CD.

Copy the folder *IBMPCprog* on your hard drive. Launch file *ZenitM.exe*

General view of the program is shown in figure 5.



Figure 5. General view of the program

Plug in technological cable 1 to the laser rangefinder, to RS 422 socket – 6785.00.00.900, to the second socket of which plug in 9M/9Π extender, second socket should be plugged to COM port of a personal computer. In case COM port is not available use USB to COM adapter. KIT BM8050.

The program is designed for control of rangefinders

This group of keys is intended for testing LRF in a mode of external synchronization. For this purpose switch " Mode " (1) should be switched in a mode " Sequential mode " (1). Thus key "Esynh En" and "Synh ON" are activated. Turning on and deenergizing of a mode of expectation of external clock pulses is carried out by keys "Esynh En" and "Esynh Dis". Control of synchro-signaling of the interface board is brought about by keys " Synh ON " and " Synh OFF ". Thus, on pressing a key " Synh ON " the board begins to generate the pulses chosen by means of the switch 2.

The program is designed for control of rangefinders

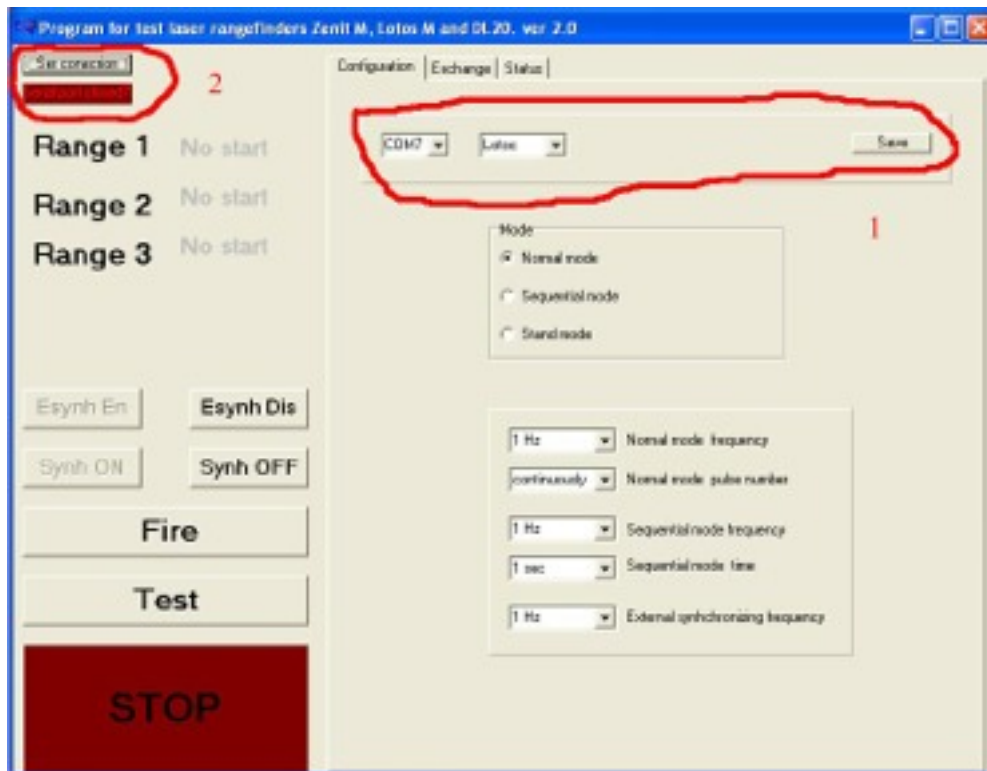

In order to start working with the program, firstly it is necessary to set up installations of COM port. On the inlay **Configuration** select the number of COM port and type of the rangefinder which is plugged in to the computer. In this case we select rangefinder. Press **Save** button to make this configuration load automatically at next start-ups of the program (1)

After plugging the cable in and setting up the COM port it is necessary to establish exchange with the rangefinder. In the top-left corner of the program window press **Set connection** button. After this under **Set Connection** button inscription **Open COM** will highlight.

In case the COM port is not set up properly or an error on USB to COM converter occurs, the program will display the following error **Check COM number or USB to COM converter**. (2). In this case set the right COM port number or reload USB to COM converter.

Now the program is ready for operation.

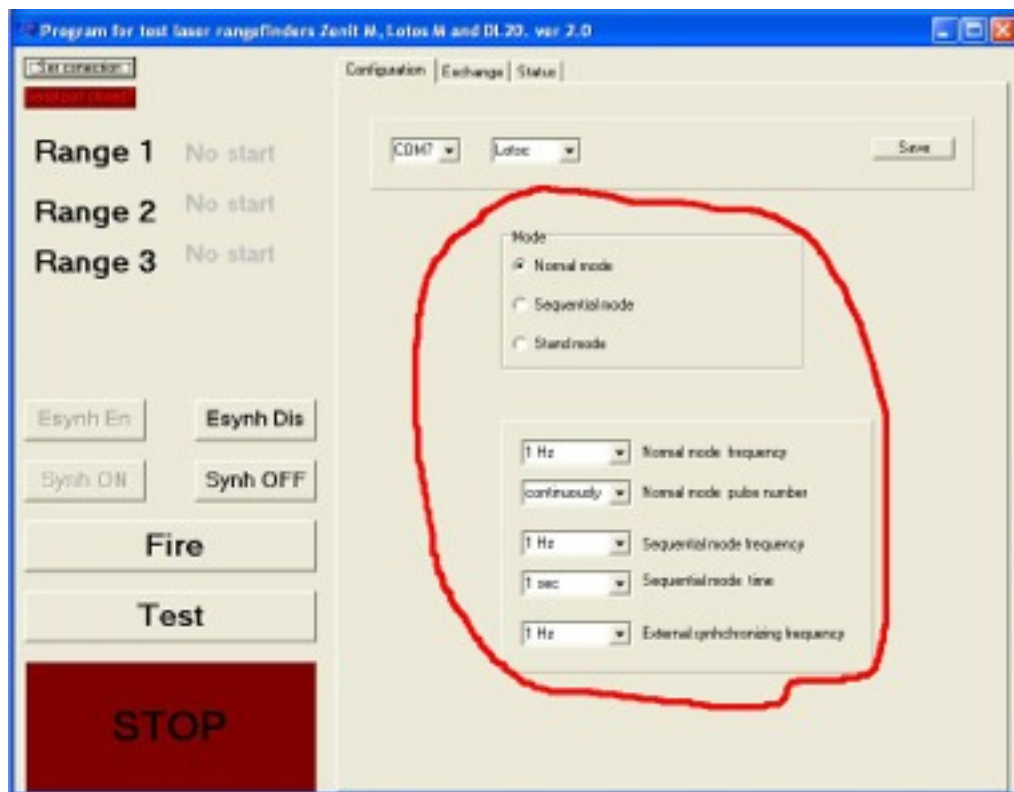

Select operating mode of the program (**Normal mode or Sequential mode**) and in submenus below select settings for the present mode.

Normal mode:

Normal mode frequency: repetition frequency of pulses

Normal mode pulse number – number of pulses (if selected **continuously** the rangefinder will work until **STOP** button is be pressed)

Sequential mode:

Sequential mode frequency: repetition frequency of pulses

Sequential mode time: time of operation of the rangefinder

In order to start the measurement, provide power supply to the rangefinder, connect the rangefinder and press **Fire** button in the left corner of program window. Depending on selected mode the rangefinder either stops measurements independently after reaching specified parameters or after pressing **STOP** button. Values of measured distances will be displayed in the top-left corner near the inscriptions Range 1, Range 2, Range 3. In case the rangefinder does not detect a target, instead of measured distance value inscription **No target** will appear.

In order to check receiving channel self-test function is provided in the rangefinder. Press **TEST** button to perform self test. In this case in the top-left corner near the inscriptions Range 1, Range 2, Range 3 values of 1024, 2048, 3072 meters will appear relatively.

All the other functions are designed for testing the rangefinder on the stands of manufacturer enterprise

3. TECHNICAL MAINTENANCE

3.1 General

Laser rangefinder should be kept clean in operating conditions.

Optical parts should always be clean. Optical parts should be cleaned from dust with clean flannel cloth wetted in alcohol-ether mixture so as to avoid scratches.

It is forbidden to touch optical parts with hands because fat stains are left on the surface.

Wipe glass surface with clean flannel cloth to remove fat stains. At severe contamination do the following:

- 1) wet cloth in alcohol and remove excess liquid by slight shaking;
- 2) wipe glass with wetted cloth several times without touching the holder;
- 3) using clean part of the cloth or another cloth, finish cleaning by moving the cloth circularly from center to edge.

When cleaning pay attention that excess of solvent (alcohol, ether) should not flow under glass holder. Technical maintenance of laser rangefinder **module** in operation includes the following types of maintenance:

- technical maintenance in operation;
- scheduled maintenance.

All types of laser rangefinder technical maintenance should be carried out together with corresponding types of maintenance of object.

3.2 Procedure of technical maintenance

3.2.1 Requirements to technical maintenance are given in Table 3.1.

Table 3.1

| Things to be checked | Technical requirements |
|--|---|
| 1 Visual examination of outer surface of all laser rangefinder module units | Cracks, dents, corrosion marks on laser rangefinder body are not allowed. Damage of braid and cables connectors are not allowed. |
| 2 Accuracy and security of fastening of all laser rangefinder module units and connectors on object | Damage of shock absorbers and releasing of bolts tightening are not allowed. |
| 3 State of optical surfaces | Cracks, fat stains, dust on outer optical surfaces as well as sweating of inner optical surfaces are not allowed |

4 TRANSPORTATION AND STORAGE

4.1 Transportation

DL-20 000 Laser rangefinder must be transported by the following means of transport:

- railway transport at a speed not more than 80 km/hour;
- motor transport on 1st class road at;
- air transport with no distance limit.

Laser rangefinder **module** can be transported under the following conditions:

- storage temperature from minus 40 to plus 70° C;
- atmospheric pressure from 81,0 to 121 kPa;
- relative humidity up to 90 % at plus 30 °C.

4.2 Storage

DL-20 000 Laser rangefinder should be kept indoors under the following conditions:

- storage temperature from minus 40 to plus 70°C ;
- air pressure (101 ± 20) kPa;
- relative humidity up to 90 % at plus 30 °C;
- normal air.

STORAGE, OPERATION And MANUFACTURER'S PRODUCT WARRANTY

Storage of the product should be carried out from the moment of acceptance at observance of storage rules set by the present technical device description and the operation manual.

The specified manufacturer's quality assurances are valid at observance of the rules set by the present description and the operation manual.

Resources, service life of the completing components comprising the product, are defined according to the operational documentation for those components.

The manufacturer guarantees conformity of the product to characteristics and to parameters in case of observance of conditions and rules of transportation, storage, unpacking, assembly, installation on object and operation of the product, set by the present description and the operation manual.

Warranty period of operation is 13 months from the date of product shipment (the moment of acceptance) (dates of Airway Bill registration) but not more than $1 \cdot 10^6$ measurements = $1 \cdot 10^6$ cycles.

ATTENTION: REPLACEMENT of PUMPING FLASH LAMP IS NOT COVERED BY WARRANTY SERVICE!

During a warranty period the manufacturer undertakes to eliminate at own expense found out defects which have arisen because of fault of the manufacturer, after submitting by Customer of technically substantiated damage claim statement.

During a warranty period the manufacturer undertakes to eliminate defects or the breakages which have arisen because of infringement by the customer of conditions and rules of transportation, storage, unpacking, assembly, installation on object, installation and the operation of the product set by the present description and the operation manual, replacement of a pumping Flash lamp with exhausted resource. In this case all charges payments concerned with repair, including researches and transportation, are undertaken by the Customer.

The manufacturer does not bear the responsibility for a product in which changes have been brought about and which was modernized or repaired without his participation.

Quality requirements do not cover malfunctions which have arisen due to wrong or negligent storage and maintenance service, misuse.

In case of infringement of seals guarantee is suspended.

Warranty service is carried out by the service of the manufacturer.

ACCEPTANCE CERTIFICATE

Laser rangefinder module «DL-20 000» № **LRF “DL-20 000”**№
serial number

has been manufactured and accepted in compliance with mandatory requirements of national standards, with active technical documentation and is considered as fit for using.

Stamp here QID chief
_____ signature _____ surname
_____ year, month, date

PACKING CERTIFICATE

Laser rangefinder module «DL-20 000» № **LRF “DL-20 000 ”**№
serial number

has been packed in compliance with requirements provided in active technical documentation.

_____ position _____ signature _____ surname
_____ year, month, date

WARRANTY CERTIFICATE

for repair within warranty period (13 months)

Laser rangefinder module «DL-20 000» № **LRF “DL-20 000”**№
serial number and date of production

_____ filled in by Manufacturer

has been purchased _____
date and stamp of Seller

ATTENTION! REPLACEMENT OF FLASHLAMP IS NOT INCLUDED IN WARRANTY SERVICE!

